



RGBW ASYMMETRIC

Infuse vibrant and emotive colour into any lighting project simply and efficiently. RGBW's Plug & Play design and patented snap-in collapsible shell module make installation quicker and easier than ever. And with an advanced thermal body, RGBW installation is possible in a range of materials including metal, wood, plaster and masonry.

TYPICAL SPECIFICATIONS

Product Code	Specifications
SNAP-SOLO-CF-AS-RGBW	Solo Body, Curved Face, Asymmetric Beam, RGBW
SNAP-SOLO-FF-AS-RGBW	Solo Body, Flat Face, Asymmetric Beam, RGBW

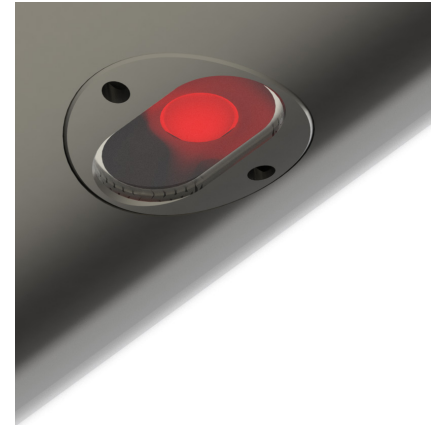

RGBW Asymmetric illuminates the path but keeps the light source out-of-sight.

CREE        

ETLus conforms to UL2108
cETL conforms to CSA C22.2 #250.0

SPECIFICATIONS*

Technical

1.4 W / 500 mA / 2.8 Vf
3000K - 165lm / 4000K - 175lm
CRI 80+ (CRI 90+ OPTION)
3 Step Macadam Ellipse
L₉₀ B₁₀ >100,000 h[†]

Optics

Polycarbonate (Standard)
Borosilicate (Option)

Material

Electropolished 316 Stainless Steel

Ambient Operating Conditions

min. -40° / max. 55°

Protection Class

Polycarbonate IP65 / IK10
Borosilicate IP67 (Option)

Electrical

Waterproof Plug & Play Connectors

Installation Surface

min. 1.5 mm Wall Thickness
min. Ø45 mm Rail (Curved Face Only)

Hole Size

Ø15 mm

Counterbore

(Required for a flush finish)
Ø16 mm x 1.6 mm (Curved Face)
Ø16 mm x 0.5 mm (Flat Face)

Control

1-10 v | DALI | DMX | ZigBee | Casambi
Blue Light Link | BasicDIM Wireless

Spec Your Led Puck

The Way You Want It!

See our Spec Your LED Puck info sheets for more configuration options

LUMINAIRE DETAIL

Distribution

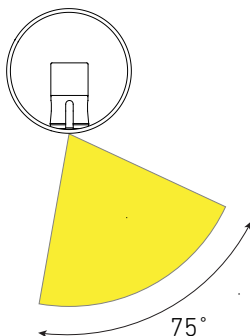

Elliptical asymmetric distribution.

Snap-In Solo Body

RGBW's thermally advanced Solo body makes it suitable for insertion into both metal and non-metal substrates.

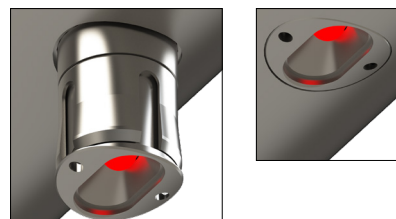

Patented push to snap-in collapsible shell module for quick installation.

Curved or Flat Face

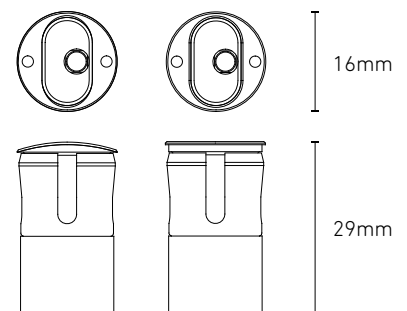

Available in curved or flat face.

*Specifications are subject to change without notice.

[†]Test for LED emitter at 500 mA and below 55°C ambient temp.



RGBW ASYMMETRIC

PHOTOMETRICS

RGBW Asymmetric has an elliptical asymmetric distribution ideal for insertion at 0-10 degrees from the vertical axis of a handrail's underside. The asymmetric beam illuminates the path but keeps the light source out of sight.

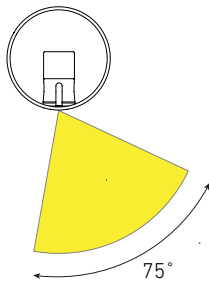

Asymmetric Beam 3000 K

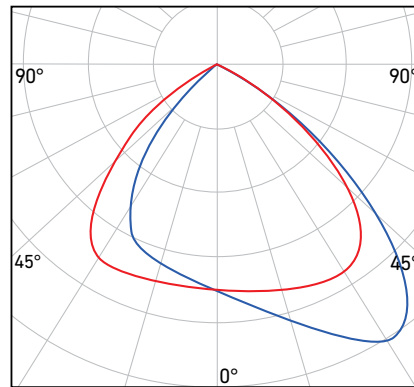

Beam Alpha 3000 K

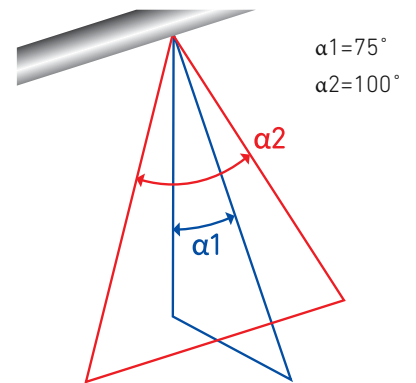

LUX GUIDE

The following guide is intended to help designers and engineers with desired lux levels. The drawing to the right shows a typical installation into a handrail. The tables list the average lux at a variety of path widths and LED spacings.

Typical Handrail Installation

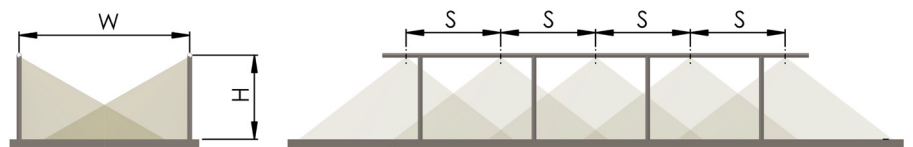

Height (H) is at 1 m

Asymmetric Beam: Light From Both Sides

Path Width (W)	1.2 m	2.0 m	3.0 m	4.0 m
LED Spacing (S)	lx	lx	lx	lx
0.5m	291	174	116	87
1.0m	145	87	58	44
2.0m	73	44	29	22

lx = average lux

CCT = 4000 K

Note: Calculations indicated are with LED module in vertical down position.

Ask Us.

Your success is important to us. Get in touch with your Planet LED Puck supplier today.